

Lens Mount (2-Axis) E-Series

Part Number: LM-2E-58-F

Mechanical Drawing:

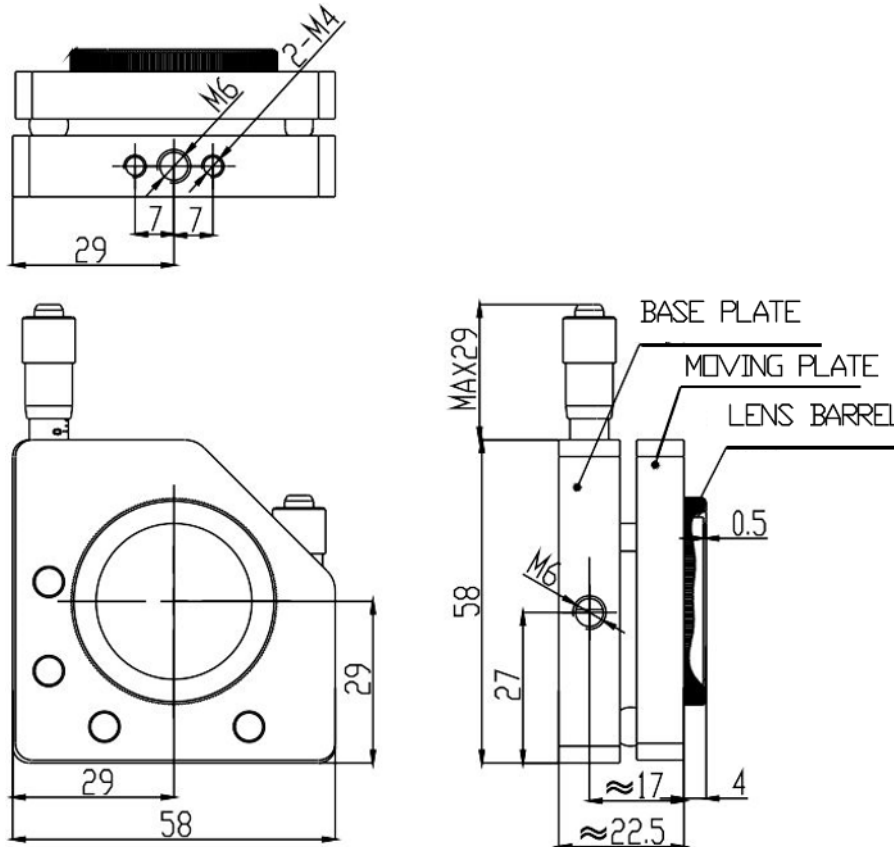

Technical Specifications:

Direction	X and Z-Axis
Dimensions (mm)	58x58
Dimensions of Lens (mm)	Φ10 – Φ30
Adjustment Range	±2°
Resolution	0.002°
Remark	Micrometer knob located on the top of the mount.

**NOTE: PROPRIETARY AND CONFIDENTIAL THE INFORMATION CONTAINED IN THIS DRAWING IS THE SOLE PROPERTY OF WAVELENGTH OPTO-ELECTRONIC(S) PTE LTD. ANY REPRODUCTION INPART OR AS A WHOLE WITHOUT THE WRITTEN PERMISSION OF WAVELENGTH OPTO-ELECTRONIC(S) PTE LTD. IS PROHIBITED.**